

**Revisions**

Issue	Date	Note
3	03/05/2018	See note 455648317

**ASSEMBLY VIEW**

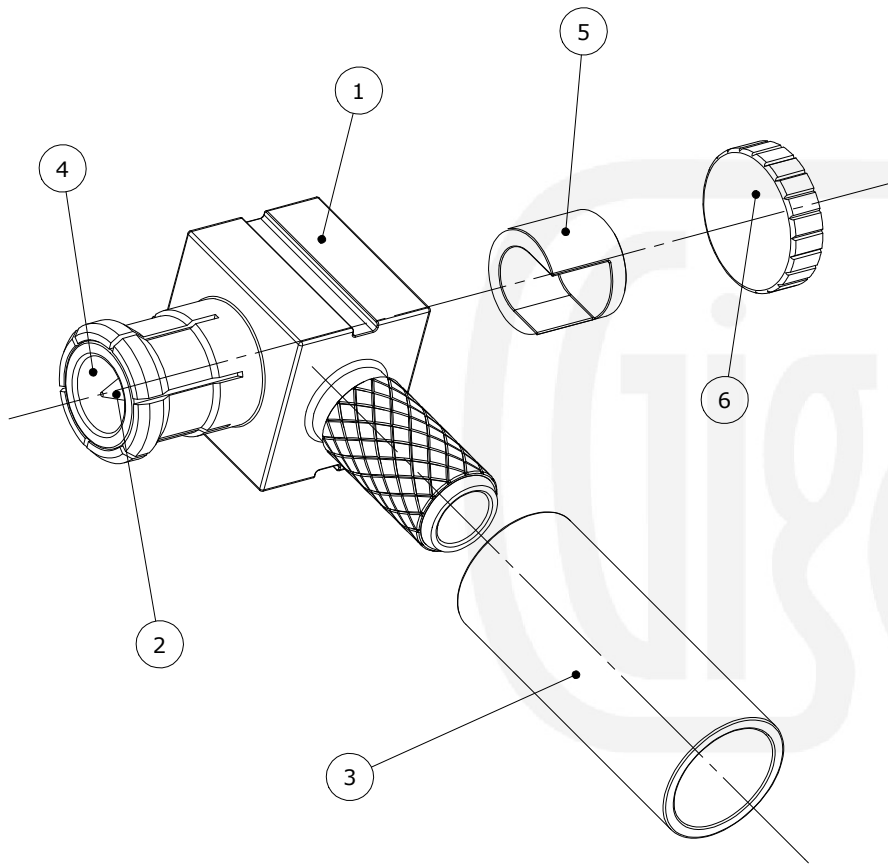

**Assembly Instructions**

1) Slide the ferrule onto the cable and strip the cable to the dimensions as shown, taking care not to nick the centre conductor or braid.

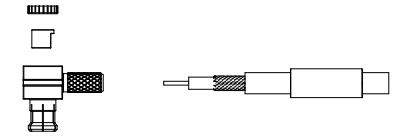

2) Insert the cable into the body, ensuring that the cable braid is on the outside of the connector mandril and that the centre core locates in the internal mounting post.

3) Slide the ferrule forward and crimp. Solder the centre core of the cable to the mounting post and fit the insulator and end cap.

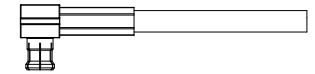

**Crimp Hex. Sizes:**

3.25mm Hex, Solder centre core

**Strip Dimensions:**

A=5.5mm, B=2.2mm, C=1.3mm

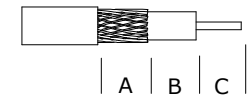

Description	Material	Finish
6 End cap	Brass	Gold
5 Insulator	ABS	White
4 Dielectric	PTFE	White
3 Ferrule	Brass	Gold
2 Pin	Phosphor Bronze	Gold
1 Body	Brass	Gold

Unless otherwise specified tolerances  
 0.5-5 = ±0.2  
 >5-30 = ±0.4  
 >30-120 = ±0.6  
 >120-315 = ±1.0  
 >315-1000 = ±1.6  
 Angles = ±5°  
 Units = mm

This document is the confidential property of Gigatronix Limited and may not be copied, reproduced or transmitted to any third party without written authorisation.



<b>Author</b>	PJP
<b>Drawn by</b>	PJP
<b>Drawing date</b>	03/05/2018
<b>Checked by</b>	DB
<b>Checked date</b>	08/05/2018
<b>Scale</b>	Not to scale

**Part Number** | MX17-0174-C01  
**Title:** MCX Crimp Right Angle Plug, Gold Plated, 50 ohms, RG174, LBC100, RG316