

Revisions

Issue	Date	Note
1	09/02/2018	See note 471898758

ASSEMBLY VIEW

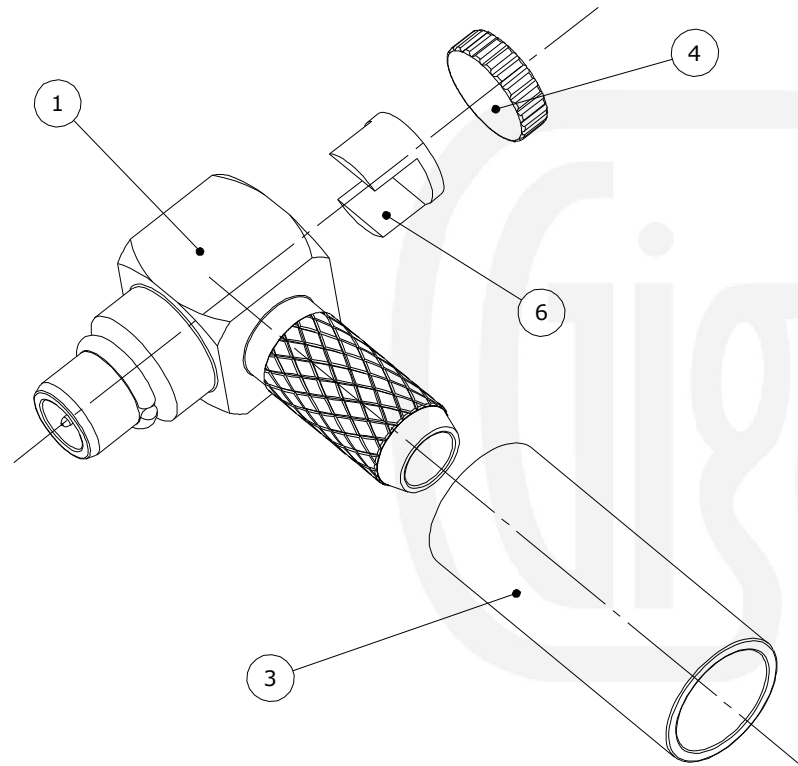

Assembly Instructions

1) Slide the ferrule onto the cable and strip the cable to the dimensions as shown, taking care not to nick the centre conductor or braid.

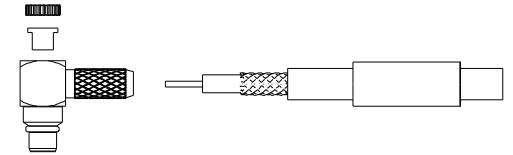

2) Insert the cable into the body, ensuring that the cable braid is on the outside of the connector mandril and that the centre core locates in the internal mounting post.

3) Slide the ferrule forward and crimp. Solder the centre core of the cable to the mounting post and fit the insulator and end cap.

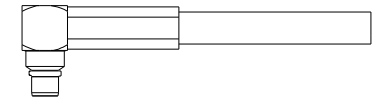

Crimp Hex. Sizes:

3.25mm Hex, Solder centre core

Strip Dimensions:

A=6.0mm, B=2.0mm, C=1.0mm

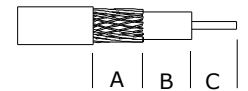

6	Insulator	POM	White
5	Dielectric	PTFE	White
4	End Cap	Brass	Gold
3	Ferrule	Brass	Gold
2	Pin	Phosphor Bronze	Gold
1	Body	Brass	Gold
	Description	Material	Finish

Unless otherwise specified tolerances
 0.5-5 = ±0.2
 >5-30 = ±0.4
 >30-120 = ±0.6
 >120-315 = ±1.0
 >315-1000 = ±1.6
 Angles = ±5°
 Units = mm

This document is the confidential property of Gigatronix Limited and may not be copied, reproduced or transmitted to any third party without written authorisation.



Author	PJP
Drawn by	PJP
Drawing date	09/02/2018
Checked by	DB
Checked date	09/02/2018
Scale	Not to scale

Part Number MM17-0179-C01

Title: MMCX Crimp Right Angle Plug, Gold Plated, RG179, RG187