

Revisions

Issue	Date	Note
2	08/02/2024	See GTXPDC/909

DATASHEET

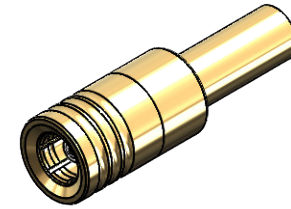

1. Mechanical

Cable Retention	Equal to breaking strain of cable
Durability	500 mating cycles
Contact Termination	Solder
Fixing Method	Crimp / Solder

2. Environmental

RoHS Compliant	Yes
Temperature Range	-65 to +165 degrees C

3. Electrical

Dielectric Withstanding	750 Volts RMS Maximum
Impedance	50 ohms
Interface Frequency	4 GHz
Working Voltage	335 Volts RMS Maximum

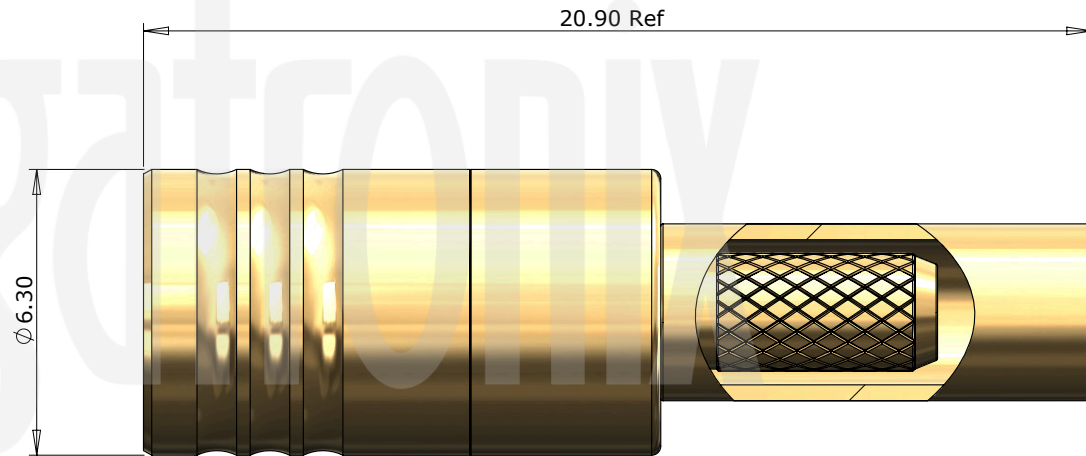

4	Dielectric	PTFE	White
3	Ferrule	Brass	Gold
2	Contact	Beryllium Copper	Gold
1	Body	Brass	Gold
	Description	Material	Finish

Unless otherwise specified tolerances
 0.5-5 = ±0.2
 >5-30 = ±0.4
 >30-120 = ±0.6
 >120-315 = ±1.0
 >315-1000 = ±1.6
 Angles = ±5°
 Units = mm

This document is the confidential property of Gigatronix Limited and may not be copied, reproduced or transmitted to any third party without written authorisation.



Author	PJP
Drawn by	PJP
Drawing date	23/02/2018
Checked by	DB
Checked date	26/02/2018
Scale	Not to scale

Part Number	MB15-0179-C01
Title:	SMB Crimp Plug, Gold Plated, RG179, RG187

Revisions

Issue	Date	Note
2	08/02/2024	See GTXPDC/909

ASSEMBLY INSTRUCTIONS

Assembly Instructions

1) Slide the ferrule onto the cable and strip the cable to the dimensions as shown, taking care not to nick the centre conductor or braid.



2) Solder the contact onto the centre core and slide the contact into the body until it captivates, ensuring that the cable braid is on the outside of the connector mandril.

3) Slide the ferrule forward and crimp.

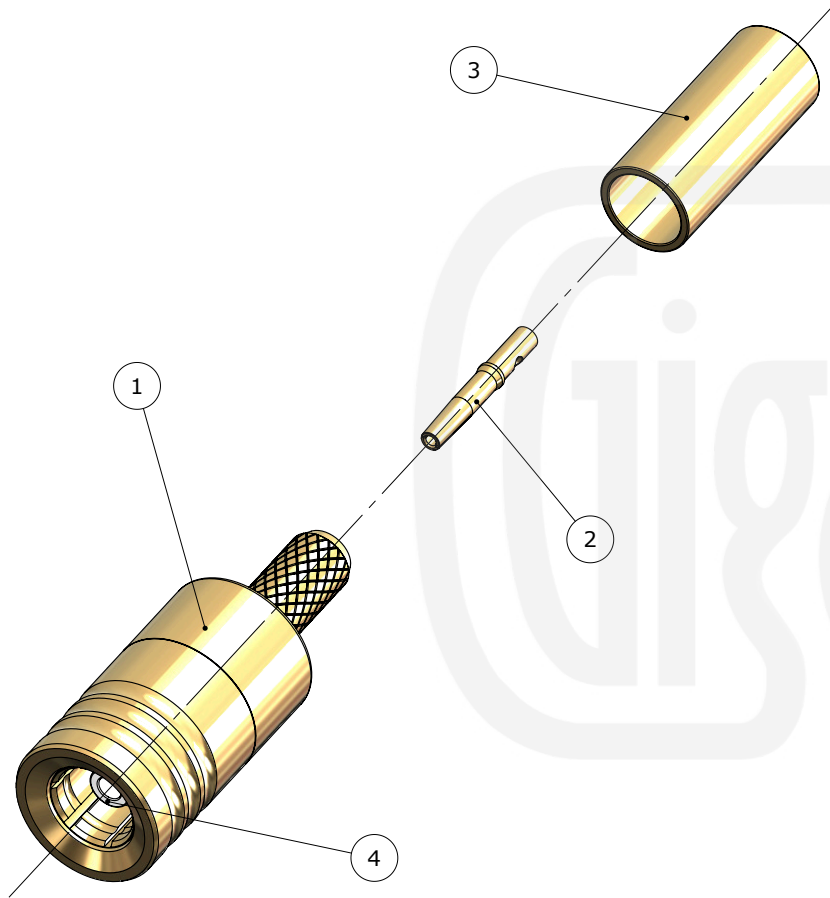

Crimp Die Sizes:
3.25mm Hex., Solder centre core

Strip Dimensions:
A=6.0mm, B=3.0mm, C=2.0mm



Description	Material	Finish
4 Dielectric	PTFE	White
3 Ferrule	Brass	Gold
2 Contact	Beryllium Copper	Gold
1 Body	Brass	Gold

Unless otherwise specified tolerances
 0.5-5 = ±0.2
 >5-30 = ±0.4
 >30-120 = ±0.6
 >120-315 = ±1.0
 >315-1000 = ±1.6
 Angles = ±5°
 Units = mm

This document is the confidential property of Gigatronix Limited and may not be copied, reproduced or transmitted to any third party without written authorisation.



Author	PJP
Drawn by	PJP
Drawing date	23/02/2018
Checked by	DB
Checked date	26/02/2018
Scale	Not to scale

Part Number MB15-0179-C01
Title: SMB Crimp Plug, Gold Plated, RG179, RG187