

Revisions

Issue	Date	Note
1	23/11/2021	See note GTXPDC/351

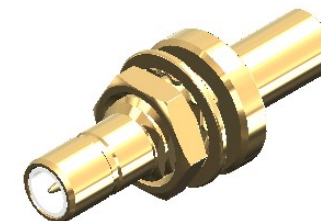

1. Mechanical

Cable Retention Equal to breaking strain of cable
 Durability 500 mating cycles

2. Environmental

RoHS Compliant Yes
 Temperature Range -65 to +165 degrees C

3. Electrical

Dielectric Withstanding 750 Volts RMS Maximum
 Impedance 50 ohms
 Interface Frequency 4 GHz
 Working Voltage 335 Volts RMS Maximum

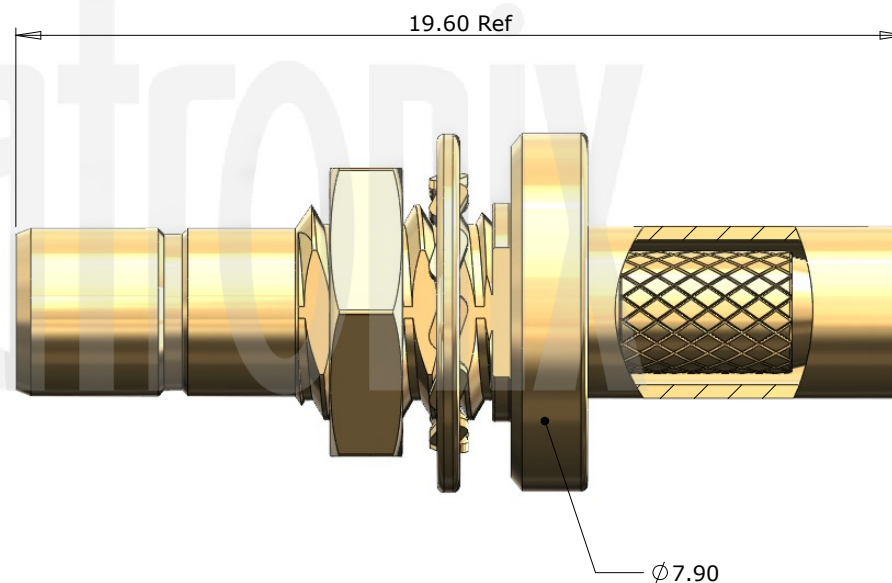
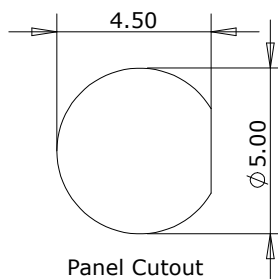

6	Lock Nut	Brass	Gold
5	Washer	Brass	Gold
4	Ferrule	Brass	Gold
3	Dielectric	PTFE	White
2	Pin	Phosphor Bronze	Gold
1	Body	Brass	Gold
	Description	Material	Finish

Unless otherwise specified tolerances
 0.5-5 = ±0.2
 >5-30 = ±0.4
 >30-120 = ±0.6
 >120-315 = ±1.0
 >315-1000 = ±1.6
 Angles = ±5°
 Units = mm

This document is the confidential property of Gigatronix Limited and may not be copied, reproduced or transmitted to any third party without written authorisation.



Author	PJP
Drawn by	PJP
Drawing date	23/11/2021
Checked by	DB
Checked date	24/11/2021
Scale	Not to scale

Part Number MB02-0179-C01

Title: SMB Crimp Bulkhead Jack, Gold Plated, RG179

Revisions

Issue	Date	Note
1	23/11/2021	See note GTXPDC/351

ASSEMBLY INSTRUCTIONS

Assembly Instructions:

1) Slide the ferrule onto the cable and strip the cable to the dimensions as shown, taking care not to nick the centre conductor or braid



2) Crimp the pin onto the centre core and slide the pin into the body, ensuring that the cable braid is on the outside of the connector mandril and that the pin is fully located

3) Slide the ferrule forward and crimp



Crimp Hex. Sizes:
3.25mm Hex, 0.72mm Square

Strip Dimensions:
A=5.0mm, B=3.5mm, C=2.5mm

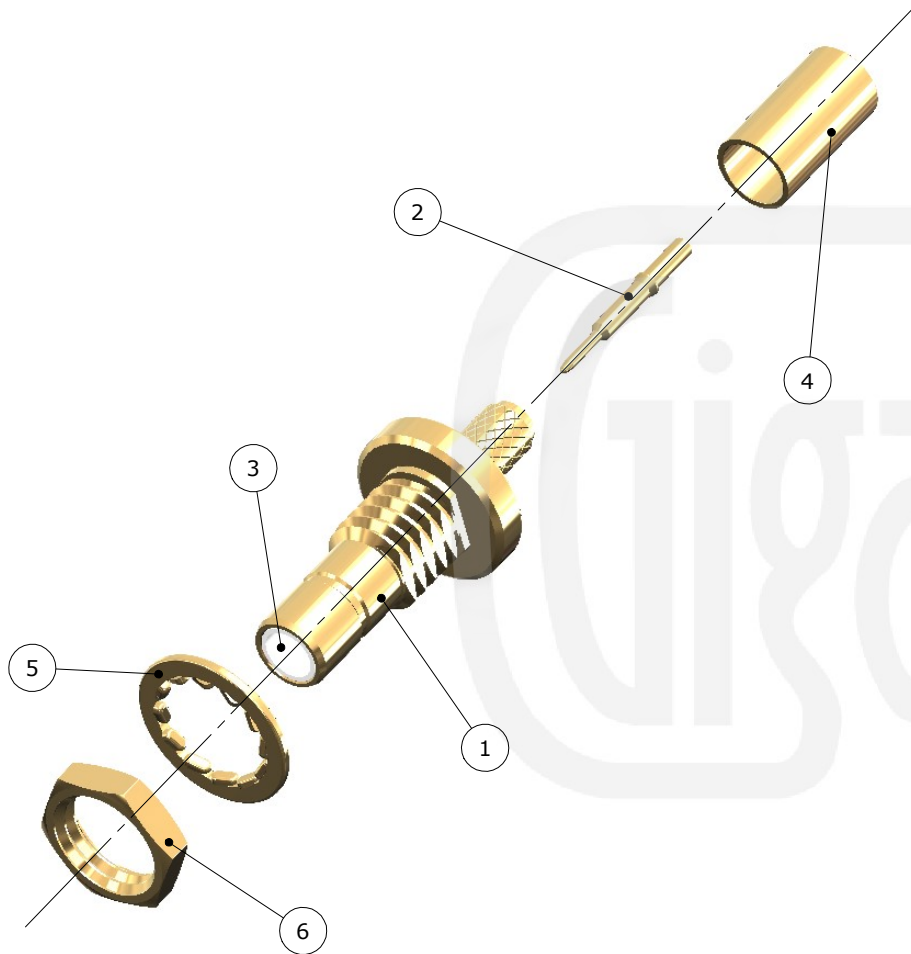

Description	Material	Finish
6 Lock Nut	Brass	Gold
5 Washer	Brass	Gold
4 Ferrule	Brass	Gold
3 Dielectric	PTFE	White
2 Pin	Phosphor Bronze	Gold
1 Body	Brass	Gold

Unless otherwise specified tolerances
 0.5-5 = ±0.2
 >5-30 = ±0.4
 >30-120 = ±0.6
 >120-315 = ±1.0
 >315-1000 = ±1.6
 Angles = ±5°
 Units = mm

This document is the confidential property of Gigatronix Limited and may not be copied, reproduced or transmitted to any third party without written authorisation.



Author	PJP
Drawn by	PJP
Drawing date	23/11/2021
Checked by	DB
Checked date	24/11/2021
Scale	Not to scale

Part Number MB02-0179-C01
Title: SMB Crimp Bulkhead Jack, Gold Plated, RG179