

**Revisions**

Issue	Date	Note
3	20/03/2024	See GTXPDC/917

**DATASHEET**

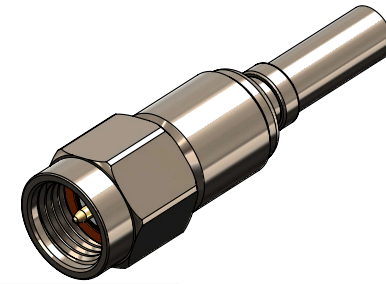

**1. Mechanical**

Cable Retention	Equal to breaking strain of cable
Durability	500 mating cycles
Fixing Method	Crimp
Mating Torque	0.79 to 1.13Nm

**2. Environmental**

RoHS Compliant	Yes
Temperature Range	-65 to +165 degrees C
IP Rating	IP68 Unmated

**3. Electrical**

Dielectric Withstanding	750 Volts RMS Maximum
Impedance	50 ohms
Interface Frequency	12.4 GHz
Working Voltage	335 Volts RMS Maximum

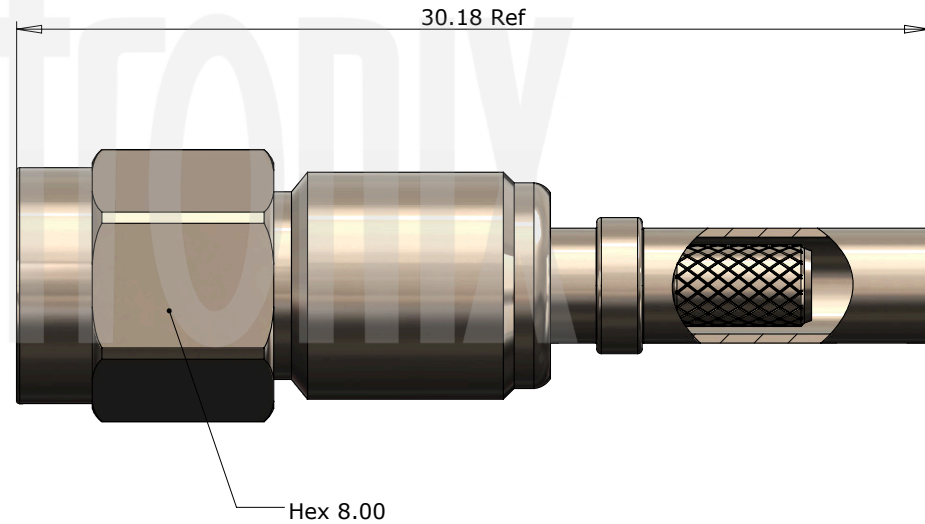

Description	Material	Finish
6 Dielectric	PTFE	White
5 Integral Pin	Phosphor Bronze	Gold
4 Pin	Brass	Gold
3 Ferrule	Brass	Nickel
2 Coupling Nut	Brass	Nickel
1 Body	Brass	Nickel

Unless otherwise specified tolerances  
 0.5-5 = ±0.2  
 >5-30 = ±0.4  
 >30-120 = ±0.6  
 >120-315 = ±1.0  
 >315-1000 = ±1.6  
 Angles = ±5°  
 Units = mm

This document is the confidential property of Gigatronix Limited and may not be copied, reproduced or transmitted to any third party without written authorisation.



<b>Author</b>	PJP
<b>Drawn by</b>	PJP
<b>Drawing date</b>	20/10/2015
<b>Checked by</b>	GP
<b>Checked date</b>	02/11/2015
<b>Scale</b>	Not to scale

<b>Part Number</b>	MA15-3161-C06WP
<b>Title:</b>	SMA Waterproof Crimp Plug, IP68, Nickel Plated, RG174, LBC100, RG316

Revisions

Issue	Date	Note
3	20/03/2024	See GTXPDC/917

ASSEMBLY INSTRUCTIONS

Assembly Instructions

1) Slide the ferrule onto the cable and strip the cable to the dimensions as shown, taking care not to nick the centre conductor or braid



2) Crimp the pin onto the centre core and slide the pin into the body, ensuring that the cable braid is on the outside of the connector mandril and that the pin is fully located

3) Slide the ferrule forward and crimp

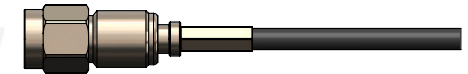

4) Apply adhesive lined heatshrink x 20mm up and over the mandril



5) Apply heatshrink x 25mm over the top of the first heatshrink

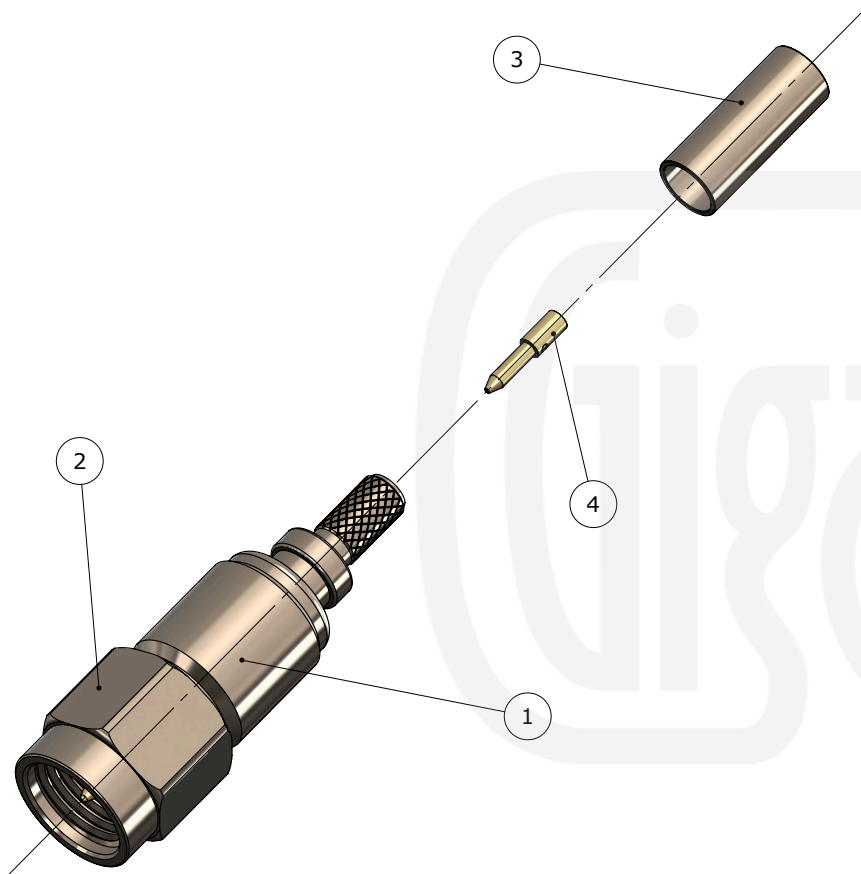

Strip Dimensions:

A=5.7mm, B=4.0mm, C=1.8mm



Crimp Die Sizes:

3.25mm Hex., 1.00mm sq.

Description	Material	Finish
6 Dielectric	PTFE	White
5 Integral Pin	Phosphor Bronze	Gold
4 Pin	Brass	Gold
3 Ferrule	Brass	Nickel
2 Coupling Nut	Brass	Nickel
1 Body	Brass	Nickel

Unless otherwise specified tolerances  
 0.5-5 = ±0.2  
 >5-30 = ±0.4  
 >30-120 = ±0.6  
 >120-315 = ±1.0  
 >315-1000 = ±1.6  
 Angles = ±5°  
 Units = mm

This document is the confidential property of Gigatronix Limited and may not be copied, reproduced or transmitted to any third party without written authorisation.



Author	PJP
Drawn by	PJP
Drawing date	20/10/2015
Checked by	GP
Checked date	02/11/2015
Scale	Not to scale

Part Number MA15-3161-C06WP

Title: SMA Waterproof Crimp Plug, IP68, Nickel Plated, RG174, LBC100, RG316