

Revisions

Issue	Date	Note
1	29/06/2023	See GTXPDC/796

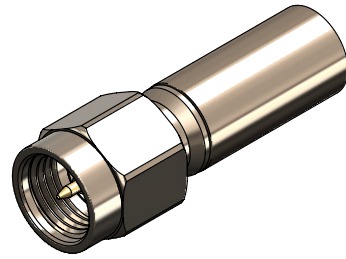

1. Mechanical

Cable Retention	Equal to breaking strain of cable
Durability	500 mating cycles
Mating Torque	0.79 to 1.13Nm (7-10 in-lbs)
Contact Termination	Solder
Fixing Method	Crimp

2. Environmental

RoHS Compliant	Yes
Temperature Range	-65 to +165 degrees C

3. Electrical

Dielectric Withstanding	1000 Volts RMS Maximum
Impedance	50 ohms
Interface Frequency	12.4 GHz
Working Voltage	500 Volts RMS Maximum

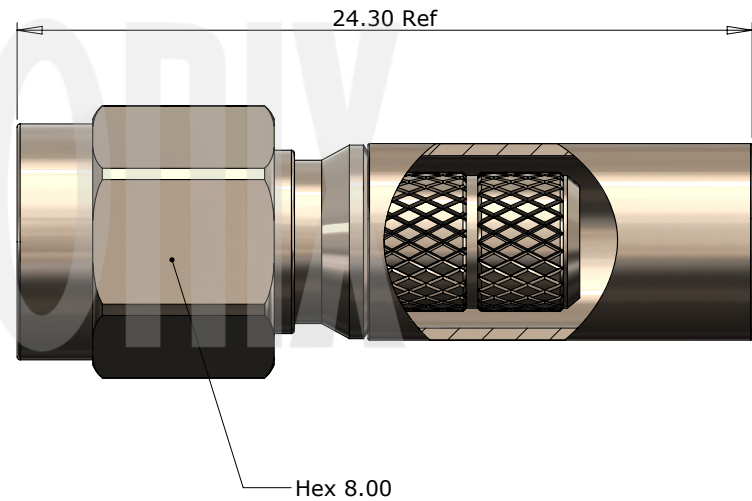

Description	Material	Finish
5 Ferrule	Brass	Nickel
4 Dielectric	PTFE	White
3 Pin	Brass	Gold
2 Coupling Nut	Brass	Nickel
1 Body	Brass	Nickel

Unless otherwise specified tolerances
 0.5-5 = ±0.2
 >5-30 = ±0.4
 >30-120 = ±0.6
 >120-315 = ±1.0
 >315-1000 = ±1.6
 Angles = ±5°
 Units = mm

This document is the confidential property of Gigatronix Limited and may not be copied, reproduced or transmitted to any third party without written authorisation.



Author	PJP
Drawn by	PJP
Drawing date	29/06/2023
Checked by	DB
Checked date	29/06/2023
Scale	Not to scale

Part Number	MA15-0400-C06
Title:	SMA Crimp Plug, Nickel Plated, RG142, RG223, RG400

Revisions		
Issue	Date	Note
1	29/06/2023	See GTXPDC/796

ASSEMBLY INSTRUCTIONS

Assembly Instructions

1) Slide the ferrule onto the cable and strip the cable to the dimensions as shown, taking care not to nick the centre conductor or braid



2) Solder the pin onto the centre core and slide the pin into the body, ensuring that the cable braid is on the outside of the connector mandril and that the pin is located in accordance with MIL-C-39012 interface dimensional requirements.

3) Slide the ferrule forward and crimp



Crimp Hex. Sizes:
5.41mm Hex, Solder centre core

Strip Dimensions:
A=9.0mm, B=1.0mm, C=2.5mm

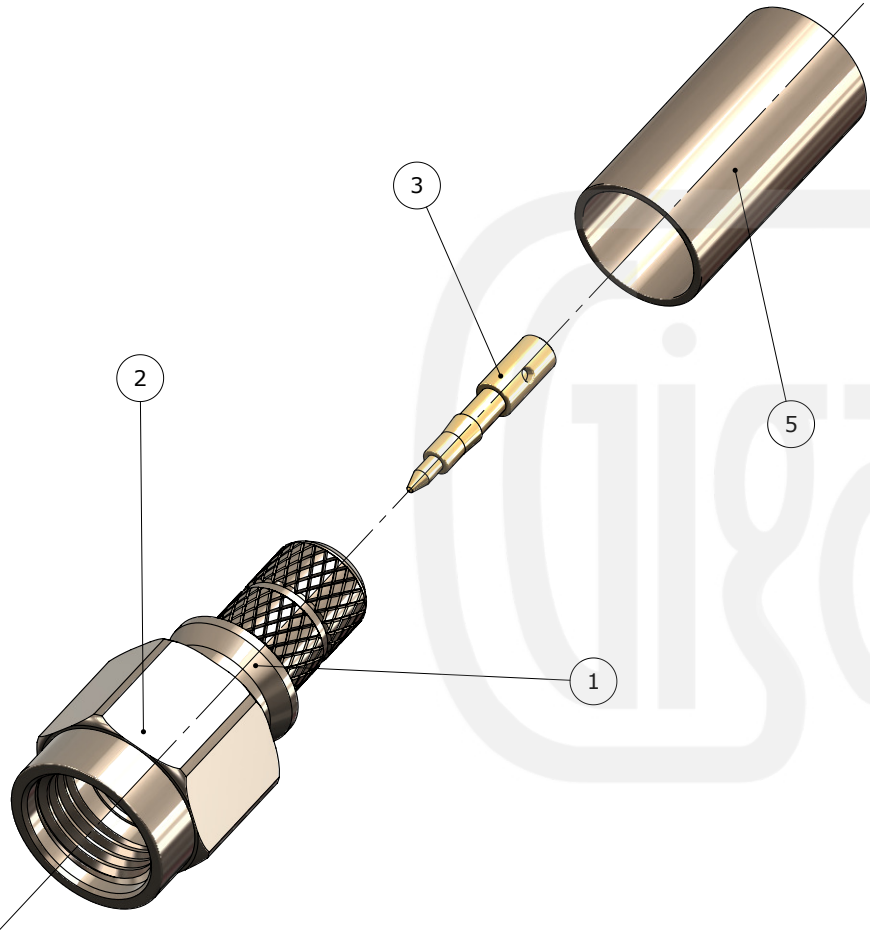

5	Ferrule	Brass	Nickel
4	Dielectric	PTFE	White
3	Pin	Brass	Gold
2	Coupling Nut	Brass	Nickel
1	Body	Brass	Nickel
	Description	Material	Finish

Unless otherwise specified tolerances
 0.5-5 = ±0.2
 >5-30 = ±0.4
 >30-120 = ±0.6
 >120-315 = ±1.0
 >315-1000 = ±1.6
 Angles = ±5°
 Units = mm

This document is the confidential property of Gigatronix Limited and may not be copied, reproduced or transmitted to any third party without written authorisation.



Author	PJP
Drawn by	PJP
Drawing date	29/06/2023
Checked by	DB
Checked date	29/06/2023
Scale	Not to scale

Part Number MA15-0400-C06
Title: SMA Crimp Plug, Nickel Plated, RG142, RG223, RG400