

Revisions

Issue	Date	Note
1	07/11/2023	See GTXPDC/860

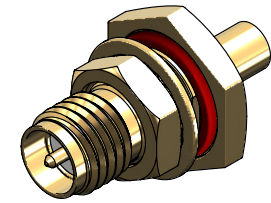

1. Mechanical

Cable Retention	27N
Durability	500 mating cycles
Fixing Method	Solder
Cable Retention	136N
Maximum Panel Thickness	2.00mm

2. Environmental

RoHS Compliant	Yes
Temperature Range	-65 to +165 degrees C

3. Electrical

Dielectric Withstanding	750 Volts RMS Maximum
Impedance	50 ohms
Interface Frequency	12.4 GHz
Working Voltage	335 Volts RMS Maximum

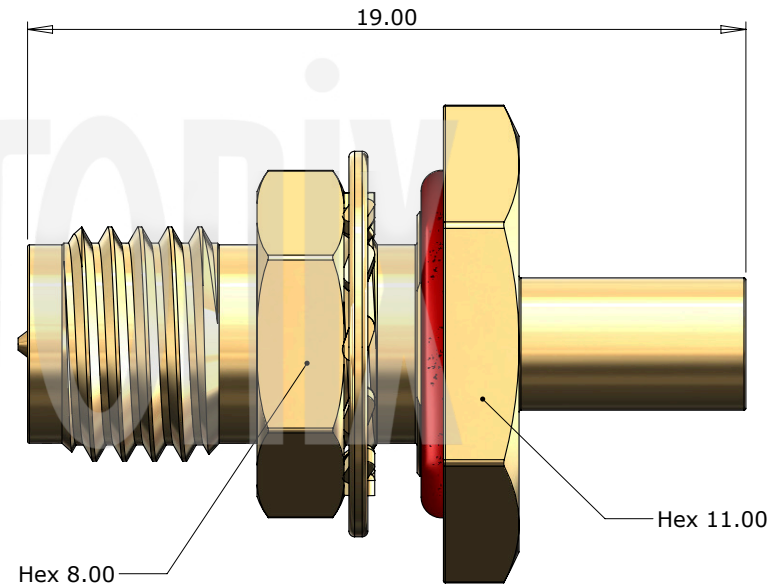
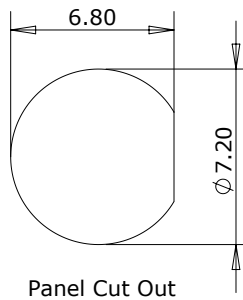

Description	Material	Finish
6 Lock Nut	Brass	Gold
5 Washer	Brass	Gold
4 O Ring	Silicone	Red
3 Dielectric	PTFE	White
2 Pin	Brass	Gold
1 Body	Brass	Gold

Unless otherwise specified tolerances
 0.5-5 = ±0.2
 >5-30 = ±0.4
 >30-120 = ±0.6
 >120-315 = ±1.0
 >315-1000 = ±1.6
 Angles = ±5°
 Units = mm

This document is the confidential property of Gigatronix Limited and may not be copied, reproduced or transmitted to any third party without written authorisation.



Author	PJP
Drawn by	PJP
Drawing date	07/11/2023
Checked by	DB
Checked date	07/11/2023
Scale	Not to scale

Part Number MA02-0405-R01-R

Title: SMA Reverse Polarity Bulkhead Jack, Gold Plated, RG405, .085 semi-rigid

Revisions

Issue	Date	Note
1	07/11/2023	See GTXPDC/860

ASSEMBLY INSTRUCTIONS

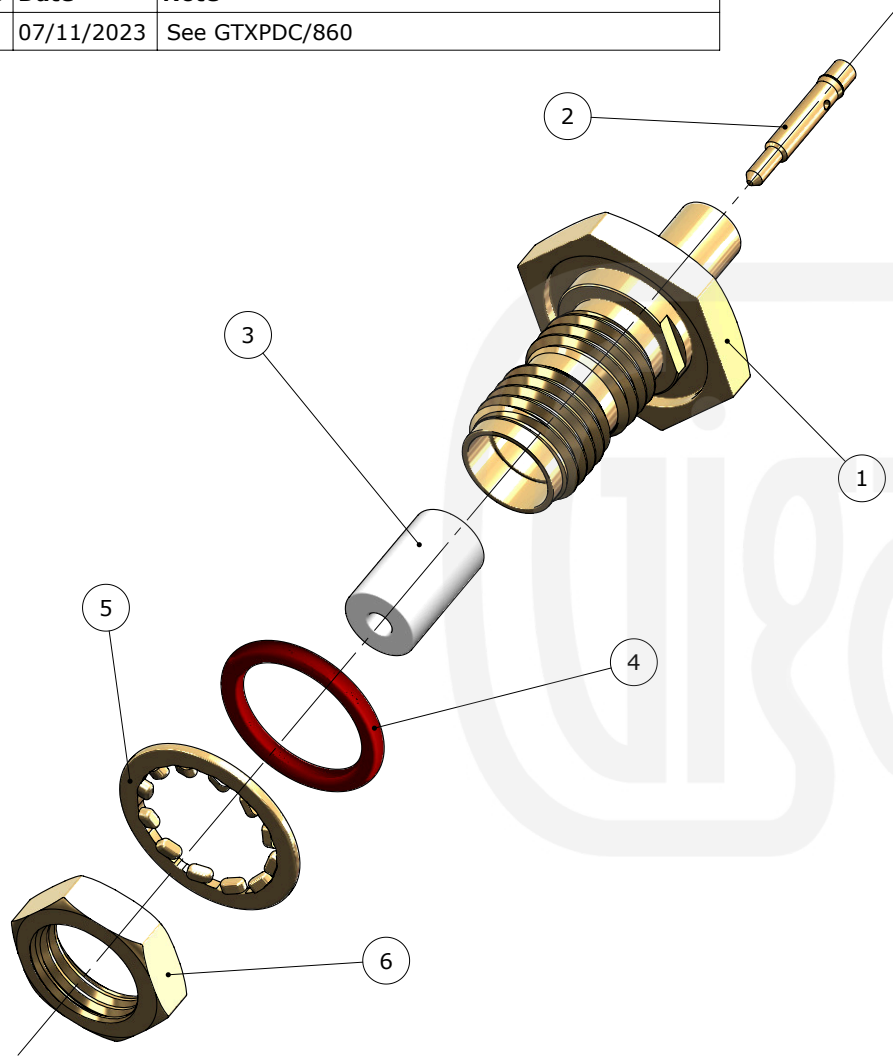

Assembly Instructions

1) Strip the cable to the dimensions as shown, taking care not to nick the centre core.



2) Solder the pin onto the centre core, then screw the body fully into an SMA Jack Gauge. Slide the pin into the back of the body until it meets the gauge and solder the cable to the mandril.

3) Fit the insulator into the front of the body using an SMA Insertion Tool.

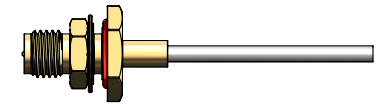

Strip Dimensions:
A=0.0mm, B=2.2mm

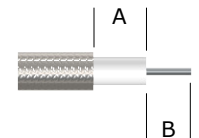

Description	Material	Finish
6 Lock Nut	Brass	Gold
5 Washer	Brass	Gold
4 O Ring	Silicone	Red
3 Dielectric	PTFE	White
2 Pin	Brass	Gold
1 Body	Brass	Gold

Unless otherwise specified tolerances
 0.5-5 = ±0.2
 >5-30 = ±0.4
 >30-120 = ±0.6
 >120-315 = ±1.0
 >315-1000 = ±1.6
 Angles = ±5°
 Units = mm

This document is the confidential property of Gigatronix Limited and may not be copied, reproduced or transmitted to any third party without written authorisation.



Author	PJP
Drawn by	PJP
Drawing date	07/11/2023
Checked by	DB
Checked date	07/11/2023
Scale	Not to scale

Part Number MA02-0405-R01-R
 Title: SMA Reverse Polarity Bulkhead Jack, Gold Plated, RG405, .085 semi-rigid