

# LBC400

# Low Loss Coaxial Cable

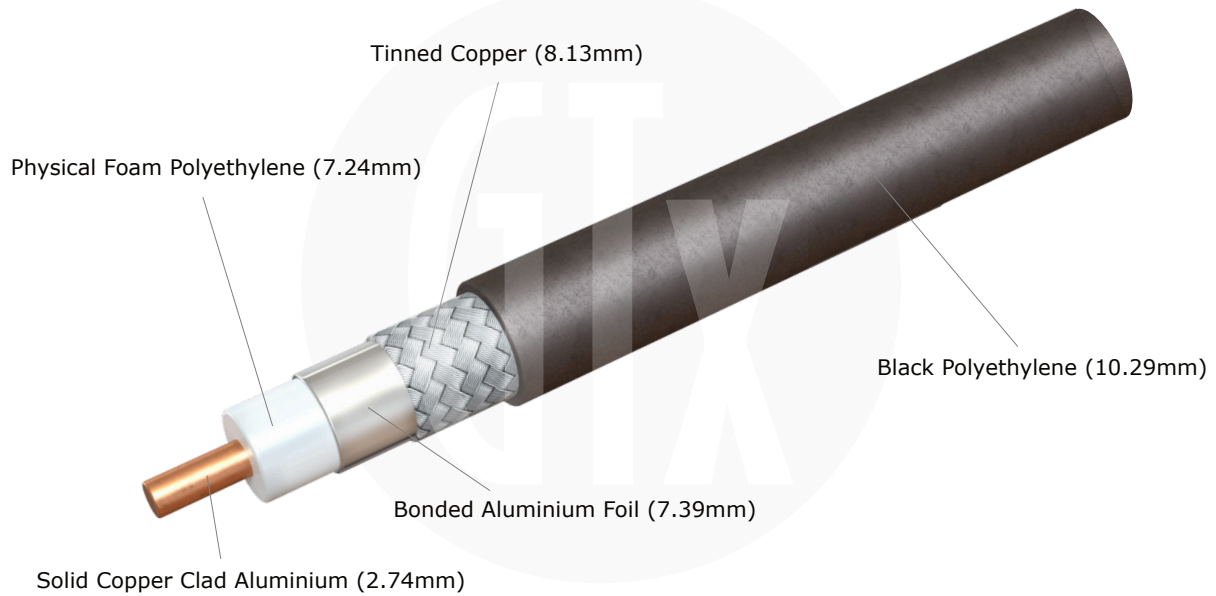

### MATERIAL SPECIFICATION

Inner Conductor	Solid Copper Clad Aluminium (2.74mm)
Dielectric	Physical Foam Polyethylene (7.24mm)
First Shield	Bonded Aluminium Foil (7.39mm)
Second Shield	Tinned Copper (8.13mm)
Jacket	Black Polyethylene (10.29mm)

### ELECTRICAL SPECIFICATION

Impedance	50 Ohms
Max. Frequency	11 GHz
Capacitance	78.0 pF/m
Velocity of Propagation	84%
Voltage Withstanding	2500V RMS Maximum

### MECHANICAL & ENVIRONMENTAL SPECIFICATION

Bending Radius (static)	25.4mm
Bending Radius (flexing)	101mm
Weight	100 gms/m
RoHS Compliant	Yes
Temperature Range	-40 to +85 degrees C

# LBC400

## Low Loss Coaxial Cable

FREQUENCY	ATTENUATION (per 100m)	AVERAGE POWER (kW)
150 MHz	5.00 dB	1.47
220 MHz	6.10 dB	1.20
450 MHz	8.90 dB	0.83
900 MHz	12.80 dB	0.58
1500 MHz	16.80 dB	0.44
1800 MHz	18.60 dB	0.40
2000 MHz	19.60 dB	0.37
2500 MHz	22.20 dB	0.33
3000 MHz	24.80 dB	0.28
5800 MHz	35.50 dB	0.21

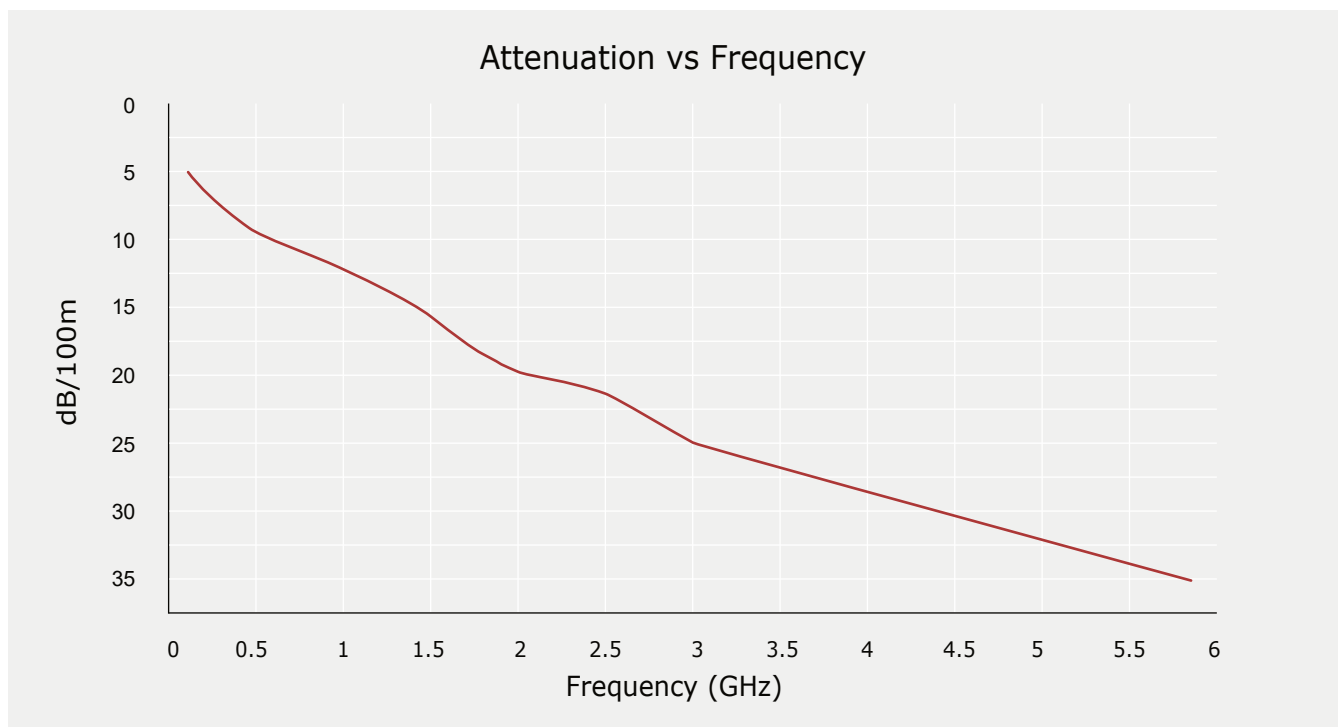

# LBC400

# Low Loss Coaxial Cable

## Declaration of Performance Regulation (EU) No. 305/2011

### PRODUCT INFORMATION

Part Number	LBC400
Description	Coaxial Cable
Application	High Performance Low Loss Flexible Coaxial Cables
Use	Communication and Data Transmission Connectivity Industries
Cable Marking	"Gigatronix LBC400 Low Loss Coaxial Cable" + metering
Packaging	"CX50-LBC400-Length", Batch Number and Date Code

### COMPLIANCE INFORMATION

Assessment	System 4
Notification Body	N/A
CPR Rating	Fca
Dangerous Substances	None

Gigatronix Ltd confirms that the products conform to requirements of the CPR standard / specifications.

Signed:



Authorised signatory

Further queries should be addressed to;

The Quality Manager  
Gigatronix Ltd  
Zullard House  
4 Downley Road  
Havant  
PO9 2NJ  
UK