

Revisions

Issue	Date	Note
4	14/08/2023	See GTXPDC/823

DATASHEET

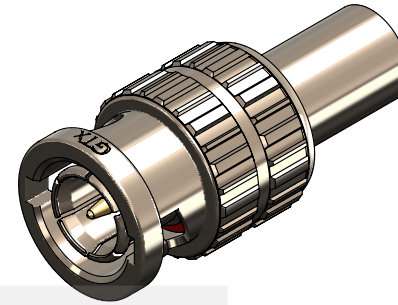

1. Mechanical

Cable Retention	Equal to breaking strain of cable
Durability	500 mating cycles
Fixing Method	Crimp
Contact Termination	Crimp

2. Environmental

RoHS Compliant	Yes
Temperature Range	-65 to +165 degrees C

3. Electrical

Dielectric Withstanding	1500 Volts RMS Maximum
Impedance	75 ohms
Interface Frequency	12 GHz
Working Voltage	500 Volts RMS Maximum

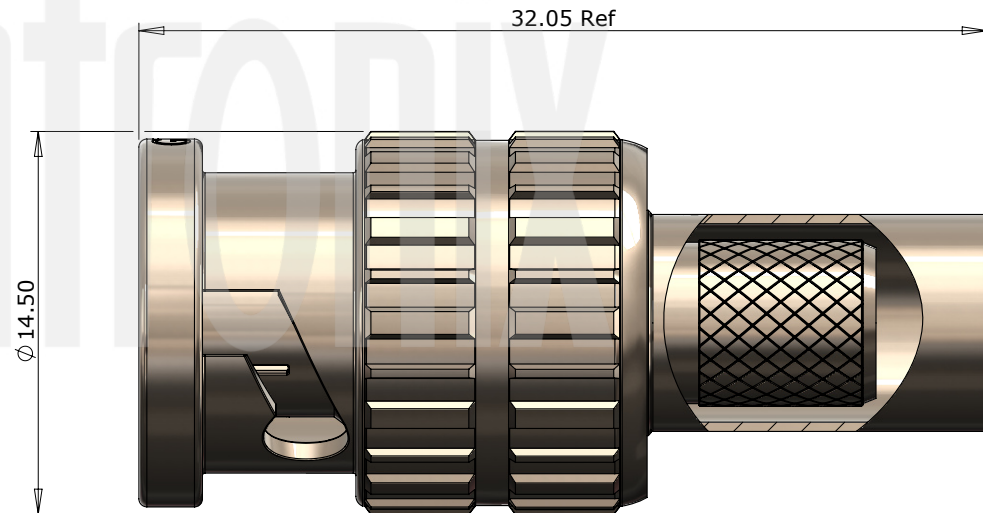

6	Gasket	Silicone	Red
5	Ferrule	Brass	Nickel
4	Dielectric	PTFE	White
3	Pin	Brass	Gold
2	Coupling Nut	Brass	Nickel
1	Body	Brass	Nickel
	Description	Material	Finish

Unless otherwise specified tolerances
 0.5-5 = ±0.2
 >5-30 = ±0.4
 >30-120 = ±0.6
 >120-315 = ±1.0
 >315-1000 = ±1.6
 Angles = ±5°
 Units = mm

This document is the confidential property of Gigatronix Limited and may not be copied, reproduced or transmitted to any third party without written authorisation.



Author	PJP
Drawn by	PJP
Drawing date	08/04/2019
Checked by	CBB
Checked date	15/08/2019
Scale	Not to scale

Part Number BN15-1694-C06X-Z
Title: BNC 12G SDI Crimp Plug, Extended Coupling Nut, Nickel Plated, Belden 1694A, 4694R

Revisions

Issue	Date	Note
4	14/08/2023	See GTXPDC/823

ASSEMBLY INSTRUCTIONS

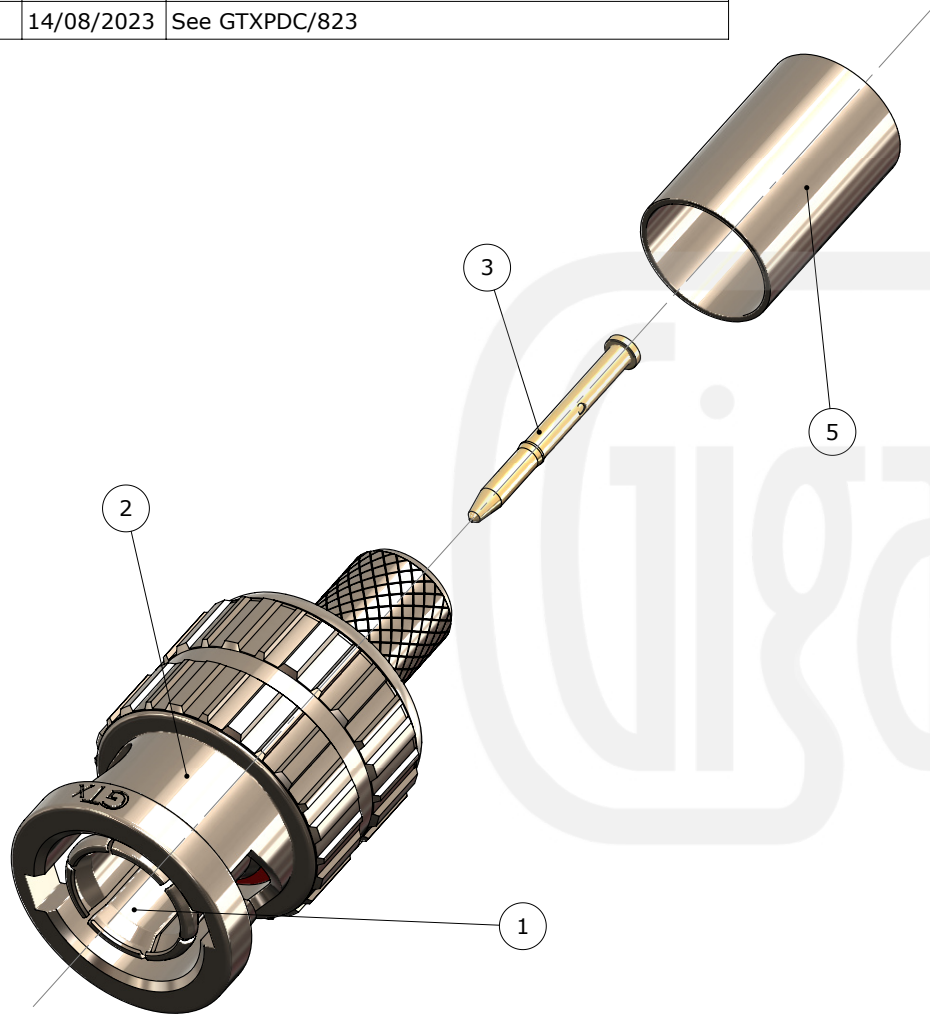

Assembly Instructions:

1) Slide the ferrule onto the cable and strip the cable to the dimensions as shown, taking care not to nick the centre conductor or braid



2) Crimp the pin onto the centre core and slide the pin into the body until it captivates, ensuring that the cable braid is on the outside of the connector mandril

3) Slide the ferrule forward and crimp

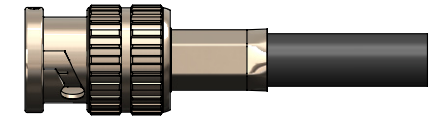

Crimp Die Sizes:

7.06mm Hex., 1.07mm sq. or Hex.

Strip Dimensions:

A=8.0mm, B=4.0mm, C=4.0mm



Description	Material	Finish
6 Gasket	Silicone	Red
5 Ferrule	Brass	Nickel
4 Dielectric	PTFE	White
3 Pin	Brass	Gold
2 Coupling Nut	Brass	Nickel
1 Body	Brass	Nickel

Unless otherwise specified tolerances
 0.5-5 = ±0.2
 >5-30 = ±0.4
 >30-120 = ±0.6
 >120-315 = ±1.0
 >315-1000 = ±1.6
 Angles = ±5°
 Units = mm

This document is the confidential property of Gigatronix Limited and may not be copied, reproduced or transmitted to any third party without written authorisation.



Author	PJP
Drawn by	PJP
Drawing date	08/04/2019
Checked by	CBB
Checked date	15/08/2019
Scale	Not to scale

Part Number BN15-1694-C06X-Z
Title: BNC 12G SDI Crimp Plug, Extended Coupling Nut, Nickel Plated, Belden 1694A, 4694R