

Revisions

Issue	Date	Note
1	01/06/2022	See note GTXPDC/522

DATASHEET

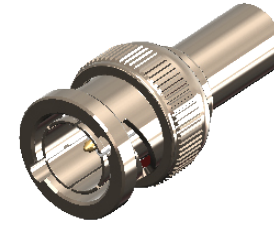

1. Mechanical

Cable Retention	Equal to breaking strain of cable
Durability	500 mating cycles
Fixing Method	Crimp

2. Environmental

RoHS Compliant	Yes
Temperature Range	-55 to +85 degrees C

3. Electrical

Dielectric Withstanding	1500 Volts RMS Maximum
Impedance	75 ohms
Interface Frequency	3 GHz
Working Voltage	500 Volts RMS Maximum

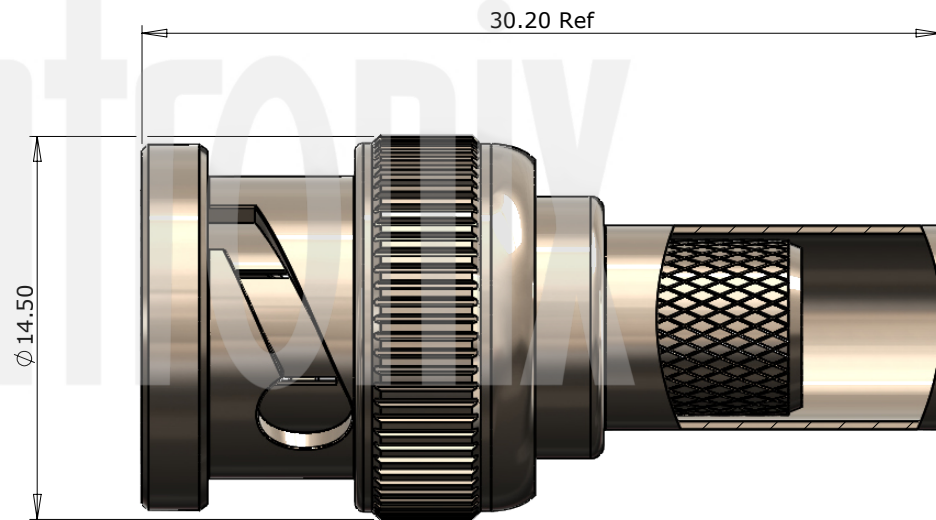

Description	Material	Finish
5 Ferrule	Brass	Nickel
4 Dielectric	Delrin	White
3 Pin	Brass	Gold
2 Coupling Nut	Zinc Alloy	Nickel
1 Body	Brass	Nickel

Unless otherwise specified tolerances
 0.5-5 = ±0.2
 >5-30 = ±0.4
 >30-120 = ±0.6
 >120-315 = ±1.0
 >315-1000 = ±1.6
 Angles = ±5°
 Units = mm

This document is the confidential property of Gigatronix Limited and may not be copied, reproduced or transmitted to any third party without written authorisation.



Author	PJP
Drawn by	PJP
Drawing date	01/06/2022
Checked by	DB
Checked date	28/06/2022
Scale	Not to scale

Part Number BN15-0100-C06
Title: BNC Crimp Plug, Nickel Plated, CT100

Revisions

Issue	Date	Note
1	01/06/2022	See note GTXPDC/522

ASSEMBLY INSTRUCTIONS

Assembly Instructions:

1) Slide the ferrule onto the cable and strip the cable to the dimensions as shown, taking care not to nick the centre conductor or braid



2) Crimp the pin onto the centre core and slide the pin into the body until it captivates, ensuring that the cable braid is on the outside of the connector mandril

3) Slide the ferrule forward and crimp

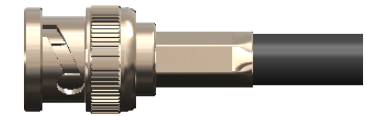

Crimp Die Sizes:
6.48mm Hex., 1.69mm Hex

Strip Dimensions:
A=8.0mm, B=5.0mm, C=4.0mm

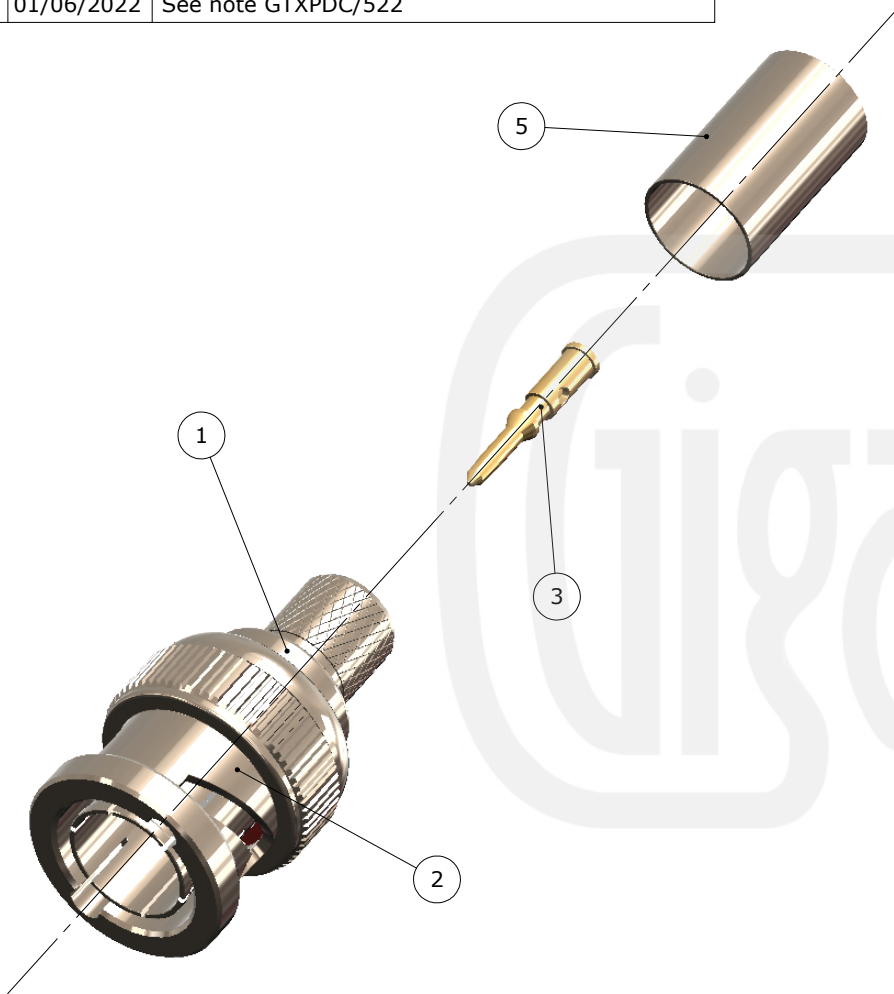

Description	Material	Finish
5 Ferrule	Brass	Nickel
4 Dielectric	Delrin	White
3 Pin	Brass	Gold
2 Coupling Nut	Zinc Alloy	Nickel
1 Body	Brass	Nickel

Unless otherwise specified tolerances
 0.5-5 = ±0.2
 >5-30 = ±0.4
 >30-120 = ±0.6
 >120-315 = ±1.0
 >315-1000 = ±1.6
 Angles = ±5°
 Units = mm

This document is the confidential property of Gigatronix Limited and may not be copied, reproduced or transmitted to any third party without written authorisation.



Part Number BN15-0100-C06
Title: BNC Crimp Plug, Nickel Plated, CT100

Author	PJP
Drawn by	PJP
Drawing date	01/06/2022
Checked by	DB
Checked date	28/06/2022
Scale	Not to scale