

**Revisions**

Issue	Date	Note
1	22/04/2022	See GTXPDC/499

**DATASHEET**

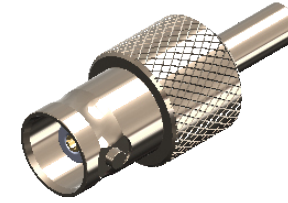

**1. Mechanical**

Cable Retention	Equal to breaking strain of cable
Durability	500 mating cycles
Fixing Method	Crimp

**2. Environmental**

RoHS Compliant	Yes
Temperature Range	-65 to +165 degrees C

**3. Electrical**

Dielectric Withstanding	1500 Volts RMS Maximum
Impedance	50 ohms
Interface Frequency	4 GHz
Working Voltage	500 Volts RMS Maximum

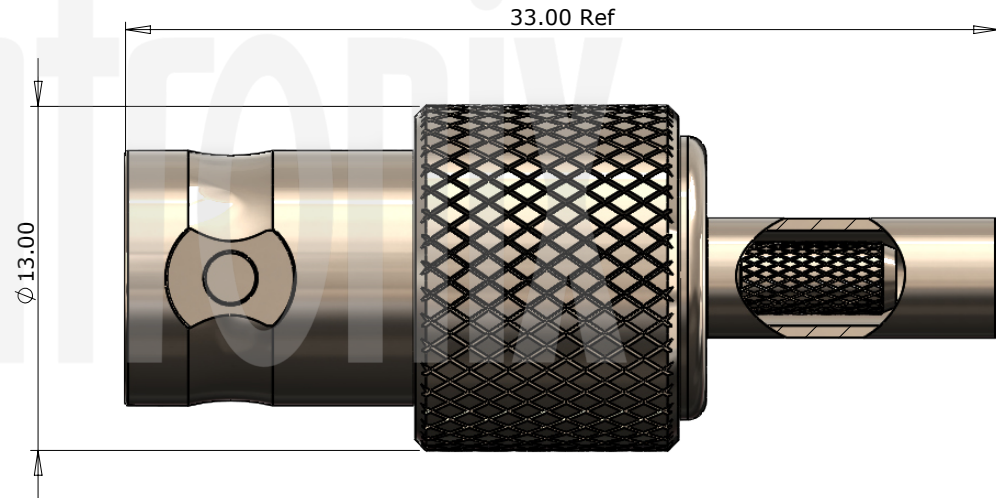

Description	Material	Finish
5 Pin	Brass	Gold
4 Ferrule	Brass	Nickel
3 Dielectric	PTFE	White
2 Contact	Brass	Gold
1 Body	Brass	Nickel

Unless otherwise specified tolerances  
 0.5-5 = ±0.2  
 >5-30 = ±0.4  
 >30-120 = ±0.6  
 >120-315 = ±1.0  
 >315-1000 = ±1.6  
 Angles = ±5°  
 Units = mm

This document is the confidential property of Gigatronix Limited and may not be copied, reproduced or transmitted to any third party without written authorisation.



<b>Author</b>	PJP
<b>Drawn by</b>	PJP
<b>Drawing date</b>	22/04/2022
<b>Checked by</b>	DB
<b>Checked date</b>	04/05/2022
<b>Scale</b>	Not to scale

**Part Number** BN10-3162-C06  
**Title:** BNC Crimp Jack, Nickel Plated, RD316

**Revisions**

Issue	Date	Note
1	22/04/2022	See GTXPDC/499

**ASSEMBLY INSTRUCTIONS**

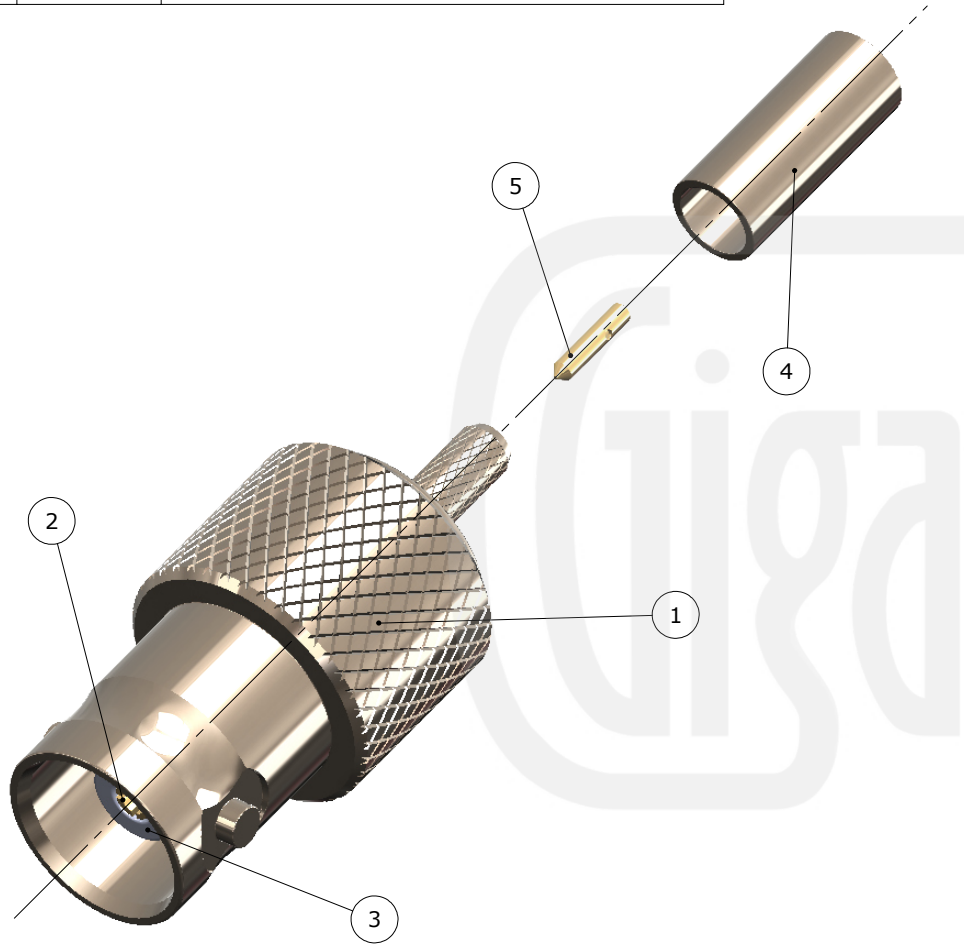

**Assembly Instructions:**

1) Slide the ferrule onto the cable and strip the cable to the dimensions as shown, taking care not to nick the centre conductor or braid



2) Crimp the pin onto the centre conductor & slide the pin into the body, ensuring that the cable braid is on the outside of the connector mandril and that the centre pin is fully located within the integral contact.

3) Slide the ferrule forward and crimp



**Crimp Hex. Sizes:**

3.83mm Hex., 0.72mm Square

**Strip Dimensions:**

A=8.0mm, B=2.0mm, C=2.5mm



Description	Material	Finish
5 Pin	Brass	Gold
4 Ferrule	Brass	Nickel
3 Dielectric	PTFE	White
2 Contact	Brass	Gold
1 Body	Brass	Nickel

Unless otherwise specified tolerances  
 0.5-5 = ±0.2  
 >5-30 = ±0.4  
 >30-120 = ±0.6  
 >120-315 = ±1.0  
 >315-1000 = ±1.6  
 Angles = ±5°  
 Units = mm

This document is the confidential property of Gigatronix Limited and may not be copied, reproduced or transmitted to any third party without written authorisation.



**Part Number** BN10-3162-C06  
**Title:** BNC Crimp Jack, Nickel Plated, RD316

<b>Author</b>	PJP
<b>Drawn by</b>	PJP
<b>Drawing date</b>	22/04/2022
<b>Checked by</b>	DB
<b>Checked date</b>	04/05/2022
<b>Scale</b>	Not to scale